

SCALE 5:1
BOTTOM CAVITY

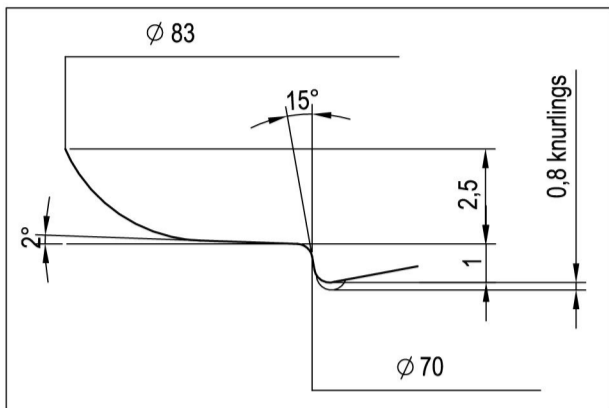

A

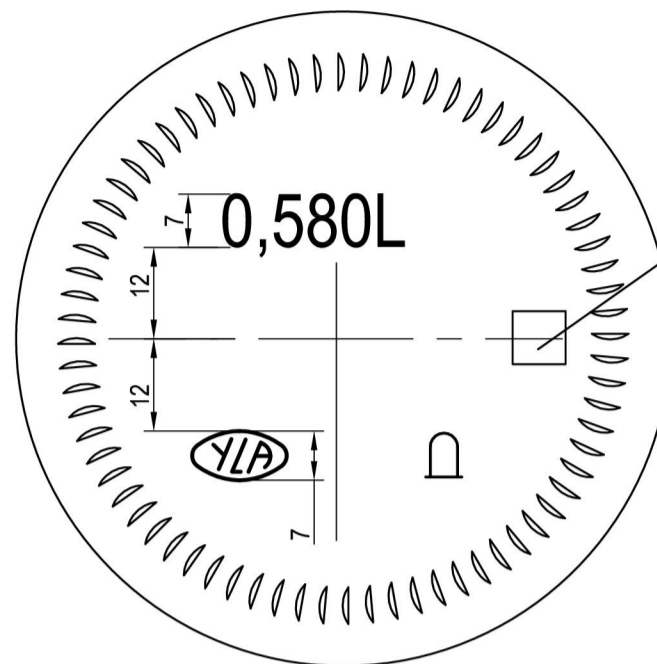

SECTION B-B
SCALE 5:1

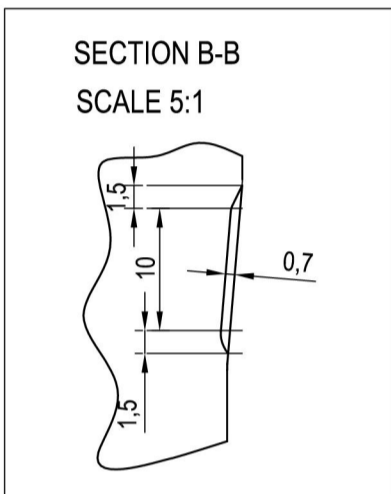

SECTION C-C
SCALE 5:1

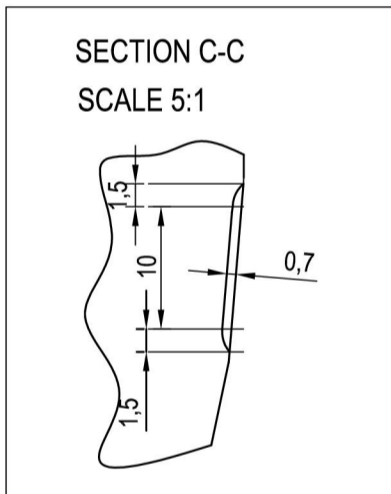

SECTION A-A

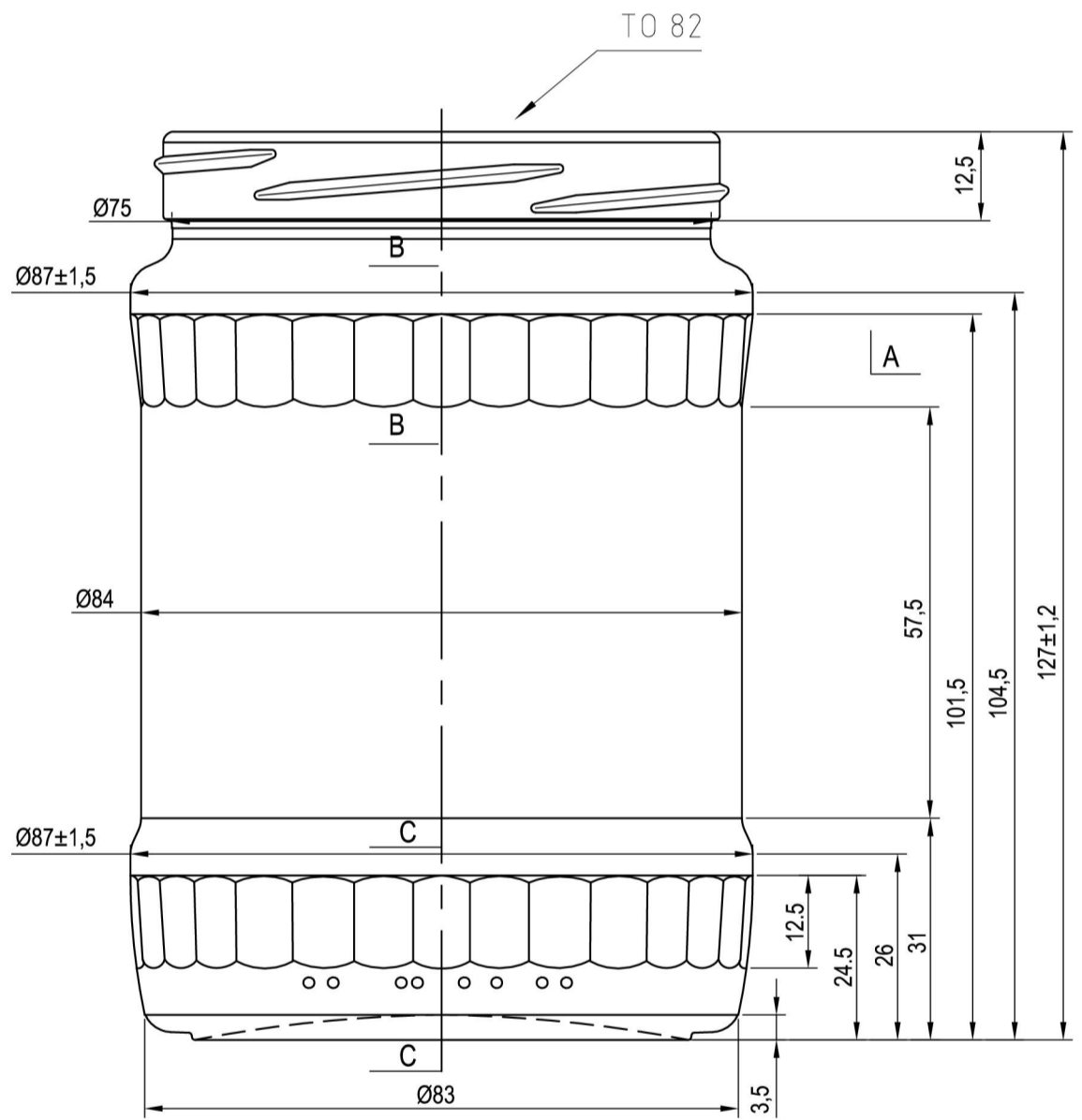
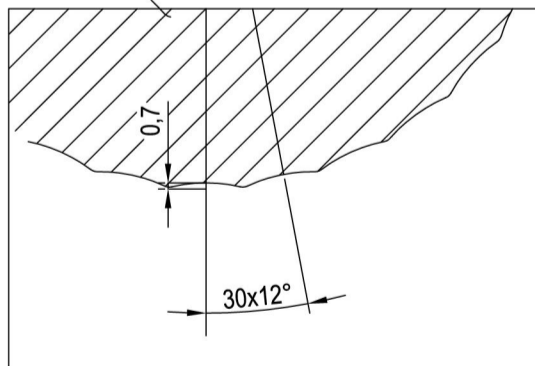

NAME	DATE	REVISIONS	MOLD No	-	A3 BA		NAME:	
01-ZL	27.08.2015	YLA- CODE	FINISH No	T049			58cl FASCETEN	
-	-	-	PROCESS	PB	MACHINE	CAT.No & DWG No:		
-	-	-	TYPE	-	TIP ANGLE	9426T049		
-	-	-	CAP.BRIMF.	580 ± 10 ml	REF MOLD	DATE 27.08.2015		
-	-	-	CAP.FILLPT.	-	FINISH	82 TO REG		SHEET 1/1
-	-	-	FILL LINE	-	DRAWN	ANGELOV		SCALE: 1:1
GR	-	-	WEIGHT	~ 290 g	CHECKED			
BG	8439071	-	COLOR	FLINT	CONFIRMED			
RO	-	-						