

DOTS CODE

DETAIL A  
SCALE 2 : 1

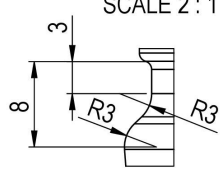

DETAIL B  
SCALE 2 : 1

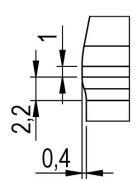

DETAIL C  
SCALE 2 : 1

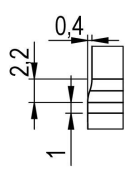

Other dimensions and information as OWENS sheets GS-217 and GS-220

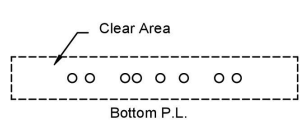

NAME	DATE	REVISIONS	MOLD No	8560		BOTTLE:		
-	-	-	FINISH No	T042		IS 4 1/4" DG	37cl VENECIJA	
-	-	-	PROCESS	PB	MACHINE	-°	CAT.No & DWG No:	
-	-	-	TYPE	-	TIP ANGLE	-	9377T042	
			CAP.BRIMF.	370 ±7ml	REF MOLD	-	DATE	15.5.2012
			CAP.FILLPT.	-	FINISH	TO 66 REGULAR	SHEET 1/1	SCALE: 1:1
			FILL LINE	-	DRAWN	KOLEV		
			WEIGHT	~190g	CHECKED	ANGELOV		
			COLOR	FLINT	CONFIRMED	CHRISTALAS		

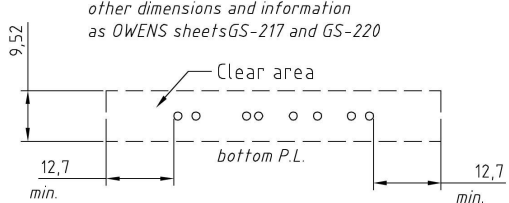
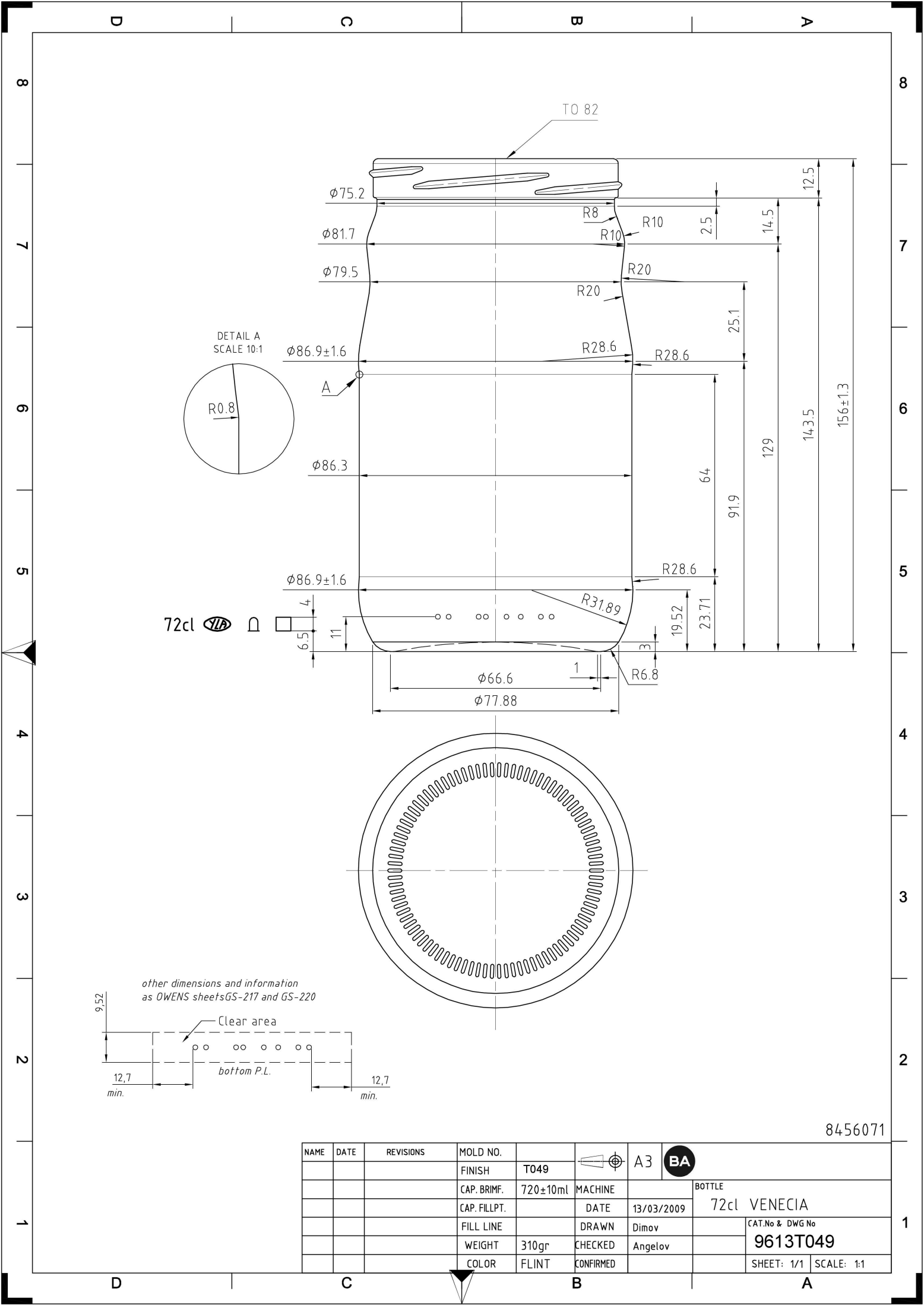

8456071

NAME	DATE	REVISIONS	MOLD NO.	A3		BA
			FINISH	T049		
			CAP. BRIMF.	720±10ml	MACHINE	BOTTLE
			CAP. FILLPT.		DATE	13/03/2009
			FILL LINE		DRAWN	Dimov
			WEIGHT	310gr	CHECKED	Angelov
			COLOR	FLINT	CONFIRMED	
						72cl VENECIA
						CAT.No & DWG No
						<b>9613T049</b>
						SHEET: 1/1 SCALE: 1:1

1